

# HD HYUNDAI MARINE SOLUTION



Beyond Waves, Beyond Boundaries

## Greetings

"We empower our customers to operate greener and more sustainable ships."

Established in 2016, HMS was founded as an independent company to become a global aftermarket service provider in the shipbuilding and marine industries. By integrating shipbuilding, engine & machinery, and electro-electric system capabilities within HD Hyundai Group, we have continued to deliver reliable ship engineering services built on 50 years of maritime expertise and insight.

Now operating under the name HD Hyundai Marine Solution, we have firmly established ourselves as a global provider of comprehensive marine solutions. Building on our strong foundation in the AM business, we continue to expand SmartCare and fleet management services in close collaboration with our customers and partners.

As the maritime industry moves toward decarbonization and digitalization, we focus on delivering practical and sustainable solutions that improve vessel performance and operational efficiency. Through our Key Account Management approach, we stay closely connected to our customers and respond with solutions tailored to their specific needs.

Looking ahead, we are taking the next step forward by leading green retrofit projects, strengthening our global logistics network, and investing continuously in R&D to address evolving environmental regulations. Through vertical integration and strategic acquisitions, we will further enhance our parts and service value chain and reinforce our competitiveness as a one-stop total solutions provider in the marine industry.

Sungjoon Kim, President & C.E.O.



## Scope of Business



## At a Glance

Record Accumulated until 2025

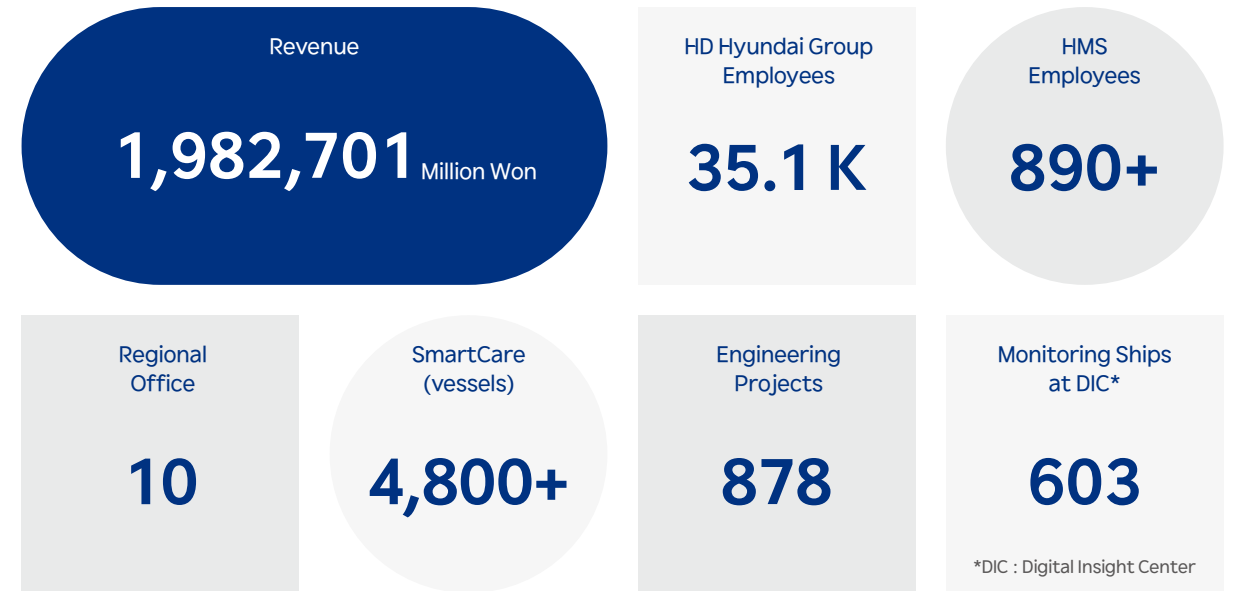

## History

2016	2017	2018	2019	2020	2021	2022	2023	2024	2025
<p><b>12</b> HD Hyundai Marine Solution inaugurated as a new corporation &amp; commenced independent business</p>	<p><b>02</b> Advanced to eco-friendly ship service business</p> <p><b>04</b> Acquired Europe corporation (Rotterdam, Netherlands)</p> <p><b>05</b> Signed information sharing contract with Hyundai Heavy Industries Engine &amp; Machinery Division</p> <p><b>10</b> Established HD Hyundai Marine Solution Americas corporation (Houston, USA)</p> <p><b>11</b> Quality Management System (ISO 9001) certification</p> <p><b>12</b> Established HD Hyundai Marine Solution Singapore corporation (Singapore, Singapore)</p>	<p><b>06</b> Newly established Digital Transformation business division</p> <p><b>06</b> Entered into bunkering service business</p> <p><b>11</b> Environment Management System (ISO 14001) certification</p> <p><b>12</b> Completed the first dual-fuel engine power station, Termonorte Engine Power Plant in Columbia</p>	<p><b>01</b> Established Digital Innovation Center for the first time in the shipbuilding industry (Busan, South Korea)</p>	<p><b>01</b> Awarded 'Labor and Management Culture Commendation of National Merit' from the Ministry of Employment and Labor</p> <p><b>02</b> Information Security Management (ISO27001) certification</p> <p><b>06</b> Acquired digital &amp; control system business</p> <p><b>12</b> Winner of 'USD 400 million Export Tower'</p>	<p><b>01</b> Attracted USD 720 million under a deal with US private equity fund KKR</p> <p><b>02</b> Launched Global Digital Center Established (Ulsan, South Korea)</p> <p><b>08</b> Acquired AIP for medium-sized regasification modules for LNG-FSRU jointly developed with Hyundai E&amp;T</p>	<p><b>03</b> Acquired AIP for Hyundai intelligent Greenhouse gas Solution Platform</p> <p><b>09</b> Established HD Hyundai Marine Solution Middle East in Dubai</p> <p><b>12</b> Joined HD Hyundai Global R&amp;D center for better synergy</p>	<p><b>05</b> Contract Signed for Retrofitting LNG Carriers with Re-Gasification Facilities for 5 Vessels</p> <p><b>11</b> Corporate Name Change to HD Hyundai Marine Solution</p>	<p><b>01</b> Entered into Ship Cyber Security Solution business</p> <p><b>02</b> Contract Signed for Digital Solution 'OceanWise'</p> <p><b>05</b> Underwent a successful Initial Public Offering</p> <p><b>08</b> Secured the first order for LNG-FSU conversion</p> <p><b>11</b> Successfully completed the first LNG vessel re-liquefaction system retrofit project in Korea</p> <p><b>12</b> Selected as an excellent work-life balance company in Korea (Ministry of Employment and Labor)</p>	<p><b>02</b> Signed MOU for OceanWise business cooperation (Weathernews)</p> <p><b>06</b> Signed 74 cumulative contracts for the Engine Power Limitation Optimization (EPLO) solution</p> <p><b>08</b> Launched 'OSR-OW', OceanWise-Weathernews integrated solution</p>



Step forward to Eco-friendly

## Engine Parts

As the licensor of HiMSEN engines, HMS is the sole supplier of genuine parts. Also, as licensees of WinGD and Everllence, we provide genuine quality products equivalent to those of the licensors, but at reasonable prices. Based on thorough blueprint information knowledge of all products manufactured by HD Hyundai Group, we can supply spares in a timely and accurate manner.

In addition, we enhance client satisfaction by serving the latest product design information that complies with recent environmental regulation changes. Based on our longstanding experience in the industry, we maintain cooperative relationship with makers, supplying HD Hyundai Group and other excellent manufacturers. As a result, we are able to supply all parts stably throughout the entire lifecycles of ships.

### Main Products

- Engine Parts (HiMSEN, Everllence, WinGD)
- Propeller, SCR

### Global Warehousing Service

Our service partners are located across the world and we operate warehouses in Korea(Busan), Europe(Rotterdam), Singapore, the United States(Houston) and Middle East(Dubai). Through these networks, we ensure the fastest delivery of genuine parts to locations preferred by clients.

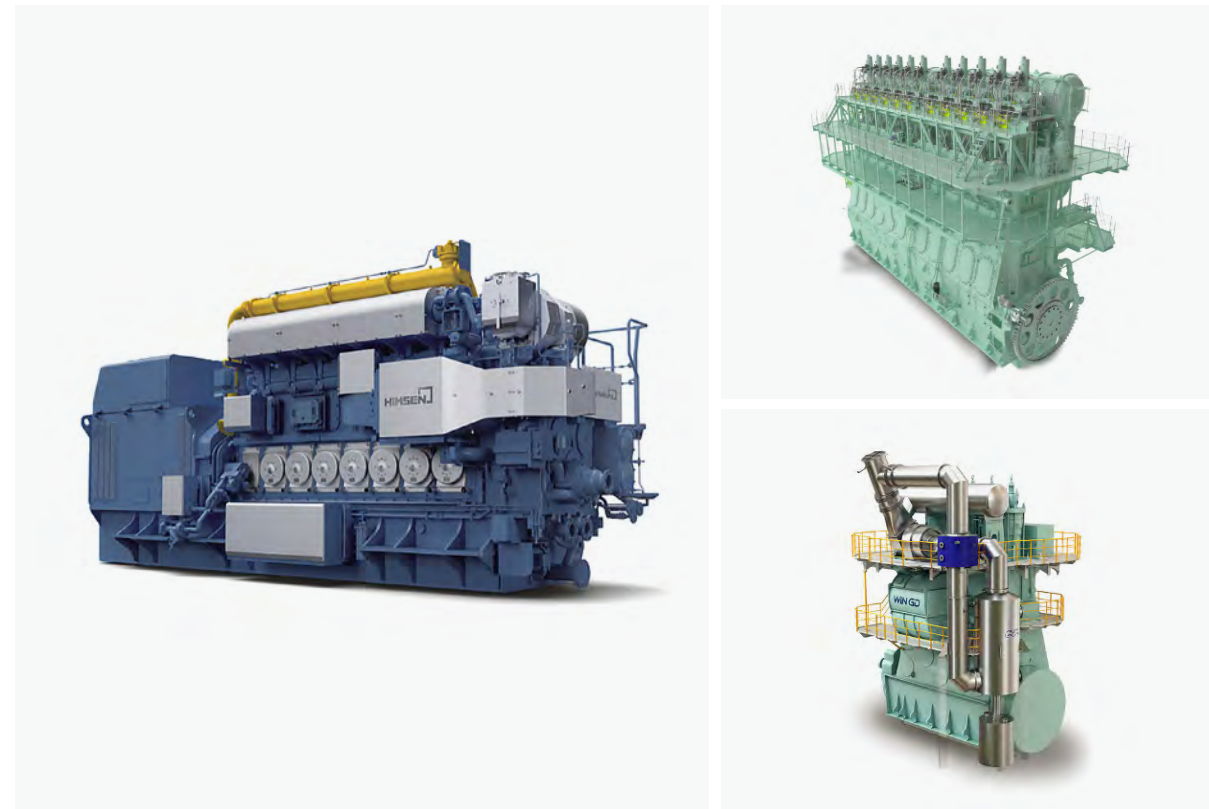

## Electric Equipment

We are the official channel for supplying genuine marine electrical products from HD Hyundai Electric, delivering original equipment and parts for generators, motors, switchboards, and circuit breakers.

With strong expertise in marine electrical systems, we go beyond simple parts supply by providing solutions that enhance operational reliability and efficiency. Leveraging extensive project experience and a global supply network, we support diverse marine applications and offer optimized electrical solutions tailored to customer requirements and operating conditions. This enables us to ensure reliable power system performance and stable parts availability throughout the vessel's lifecycle.

### Equipment For Initial Spare Parts



Breakers (ACB/VCB)



Switchboard



Motor



Generator

### Service We Provide By Pre-D/D Health Check

Pre-dry dock inspections and electrical equipment health checks enable us to develop optimized service solutions by combining customer requirements with our proven expertise.

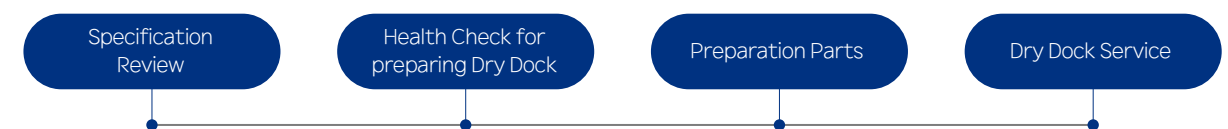

# Marine Equipment

HMS provides spares & service for the Marine equipment, installed to the vessel. Especially, we provide Genuine products in same quality with the original maker at reasonable prices by virtue of strong business relationships with the KOREAN makers & manufacturers from Newbuilding.

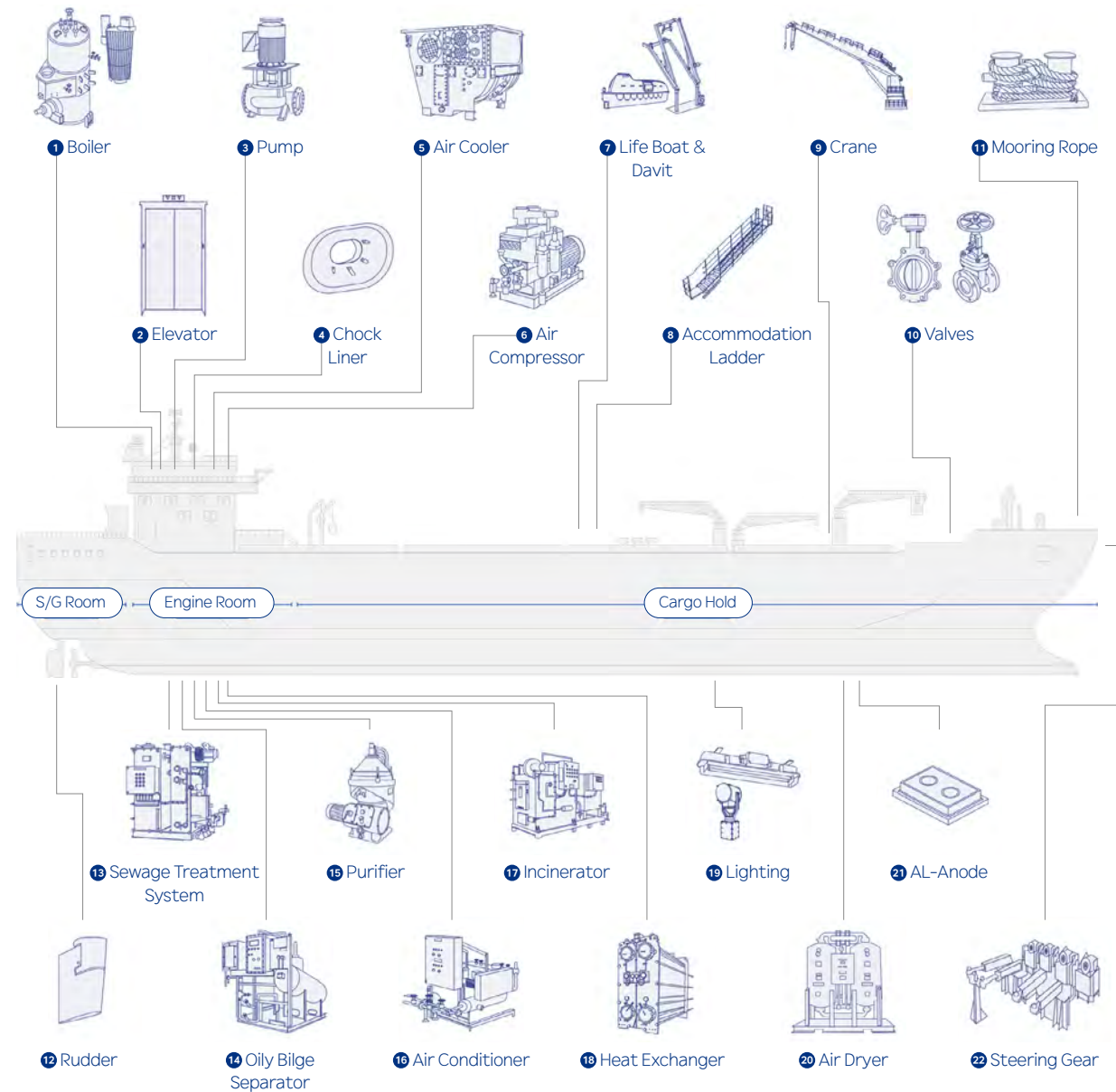

With on-hand historic data from Newbuilding(HHI, HSHI, HMD) & Warranty



Offering Recommended spare part List per each machinery/ maker

→ Spare & service solution for initial & Dry dock package

# BWTS/ COP/ Side Thruster

## Eco Fluid Machinery

HMS is Genuine Part & Service Supplier for below equipment.

- **HiBallast**, Ballast Water Treatment System
- **Hi-COPS**, Cargo Oil Pump System
- **Hyundai Thruster**, Side Thruster
- **Hi-GAS**, Fuel Gas Supply System
- **Hi-REGAS**, Re-gasification Unit
- **Hi-ERS**, Re-liquefaction System
- **Hi-ALS**, Air Lubrication System

HD HMS offers a comprehensive Maintenance Services designed to help vessels achieve long-term operational reliability and full compliance with international regulations.

- **Initial & Critical Spare Parts**
- **Dry Dock Repair**
- **LTSA(Long Term Service Agreement)**



Hi-CHS



Hi-ERS



Hi-ReGAS



Hi-GAS

# Long Term Service Agreement (LTSA)

## Always In Top Shape

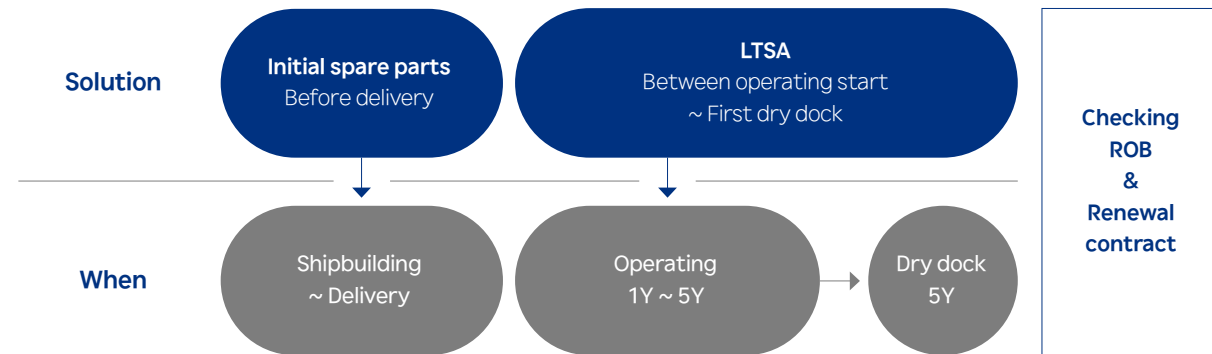

We, HD Hyundai Marine Solution (HD HMS), would like to suggest two (2) simple ways in order to keep your vessel as fit as a fiddle.

- **Initial Spare Parts:** It is quite essential to have minimum spare parts to maintain stable operation against unexpected problems. We highly recommend to prepare for these crucial parts before delivery.
- **LTSA:** It is the most efficient and cost-competitive comprehensive service covering from scheduled maintenance to dry dock inspection. We will take care of your heart of vessel from A to Z.

## Scope Of Initial and LTSA

<b>Initial</b>	<b>Must have</b> Major OVHL parts	<b>Nice to have</b> Long lead time parts	<b>Critical</b> Electronic and Sensor
<b>LTSA standard</b>	<b>Spare parts</b> Long life genuine components	<b>Service</b> Performed by HD HMS TECH	
	<b>Academy</b> On/Offline crew training	<b>HD. Voyage</b> Web based customer portal	
<b>Extra options</b>	<b>Analysis &amp; Report, Voyage Management, CII rating estimation, Onshore Service</b> * Some functions need integrated smart ship solution (ISS) on your ship.		

## Reference

Over 800 vessels of 60+ customers across the globe are managed by HD HMS's special management program since 2018.

Since 2025, more than 20 vessels has renewed their contracts with HD HMS.

## 1 Initial spare parts for reducing downtime

	Low Speed Engine	Medium Speed Engine (HiMSEN)
<b>Must have</b>	Overhaul spares of major parts for two (2) cylinder	Overhaul spares of major parts for one (1) engine
<b>Nice to have</b>	Long lead time parts Casting, forging, bearings	Long lead time parts Casting, forging, pumps
<b>Critical*</b>	Various electronic & Gas components	Governor, various sensor & Gas components

International Association of Classification Societies(IACS) is advising to have spare parts for dual fuel and electronically controlled engine, recommended by the designer/ manufacturer.

By providing recommended spare parts, HD HMS aims to enhance your fleet's Competitiveness. We carefully analyze and suggest necessary safe spare parts based on decades of accumulated experience.

Mixed **1** initial and **2** LTSA service is available for more water-tight management.

## 2 LTSA, tailored management just for your vessel

<b>Period</b>	From one (1) to five (5) years and dry dock			
<b>Scope</b>	Main Engine	Generator Engine	Electric equipment	SCR, BWTS and ETC.

HD HMS provides spare parts and services for major overhaul works according to Time Between Overhaul (TBO) with a fixed rate from one (1) to three (3) years and/or five (5) years extensively.

Scope of parts and services are adjustable upon the request of individual vessel and customers. For example, customer could exclude some of the parts that are already on the vessel(Remaining On Board). This helps stock management efficiently preventing duplicate purchase of unnecessary parts.

### LTSA overhaul interval and needed parts (Sample of X72DF Main Engine)

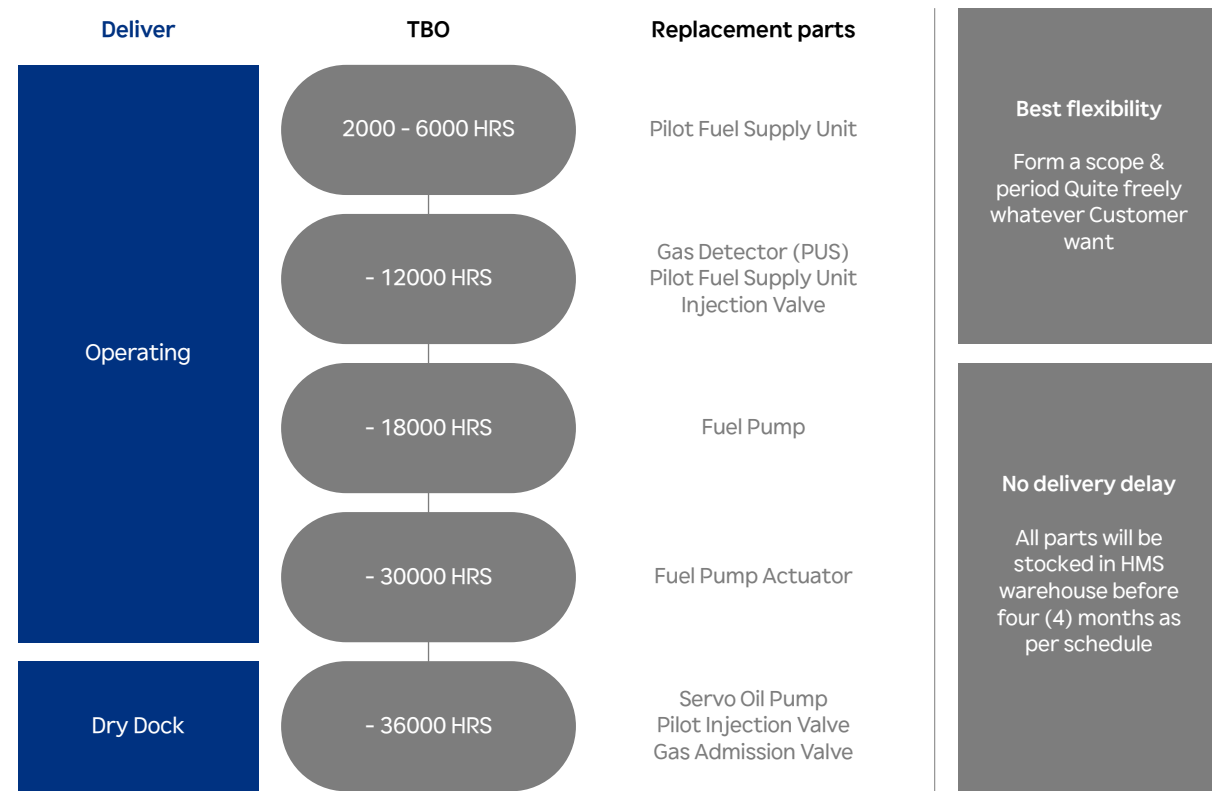

\* Major parts will be supplied and include all necessary consumable parts.

### Key benefit

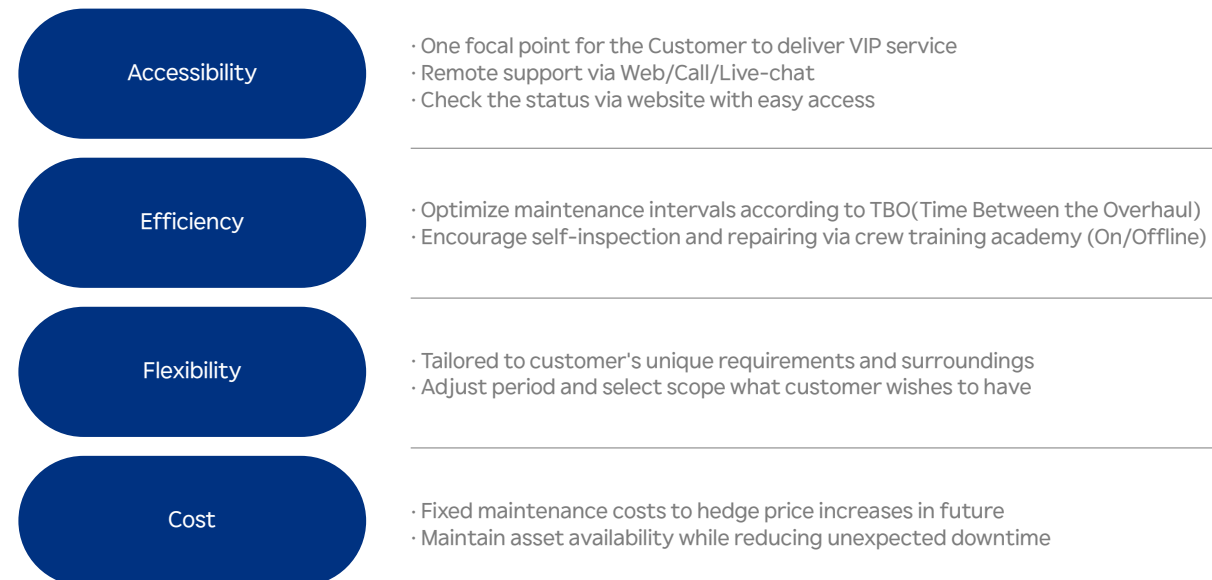

## De-Carbonization Solution

HMS helps customers meet the IMO strategy on reducing GHG emissions for ships with various optimal solutions. These solutions include technology optimization and operational efficiency improvement to comply the Energy Efficiency Existing ship Index (EEXI) and to enhance the Carbon Intensity Indicator (CII).

HMS can enhance operational efficiency with Energy Saving Devices (ESD) that improve performance based on simulation. Our customers can choose from a range of ESD options and combine them for maximum energy savings.

Category		Key Factor Reduction Efficiency (%)	Lead Time (Months)	Recommended Vessel
Dual Fuel Engine Conversion	LNG Dual Fuel Ship	20~25%	20~24	CNTR, VLCC, VLOC
	LPG Dual Fuel Ship	13~18%	18~21	VLGC
	Methanol Dual Fuel Ship	Abt. 11%/100% (Fossil/Bio-&e-)	20~24	CNTR, Bulk, Tanker
Emission Control at Berth	Alternative Maritime Power <sup>1)</sup>		5	CNTR, PCTC, Tanker
	Alternative Maritime Steam Production <sup>2)</sup>	TBD	6	All Except for Tanker
Co2 Emission	Rotor Sail	3~8%	13~14	Bulk Carrier, Tanker
	Air Lubrication System	3~6%	11~12	LNGC, PCTC, RORO
	Engine Part Load Optimization <sup>3)</sup>	1~4%	6	All
	Shaft Generator	3~6%	11~12	CNTR, LNGC
	Waste Heat Recovery System	-	8~9	All
	Hi-Fin	0.5~1.5%	4~5	All
	Hi-PSD	2~6%	9~11	All (excl. LNGC)
SOx Emission	Bulbous Bow+ Propeller Re-design	4~7%	10~12	CNTR
	Exhaust Gas Cleaning System	-	5	Above Aframax Tanker
CH4 Emission	MSS	40%	6	HiMSEN DF Engine
	ICER	38~47%	14	X-DF Engine

1) Mandatory item specified in ports (USA, Europe, China) / 2) Zero carbon emission with AMP / 3) Fuel saving at slow steaming operation

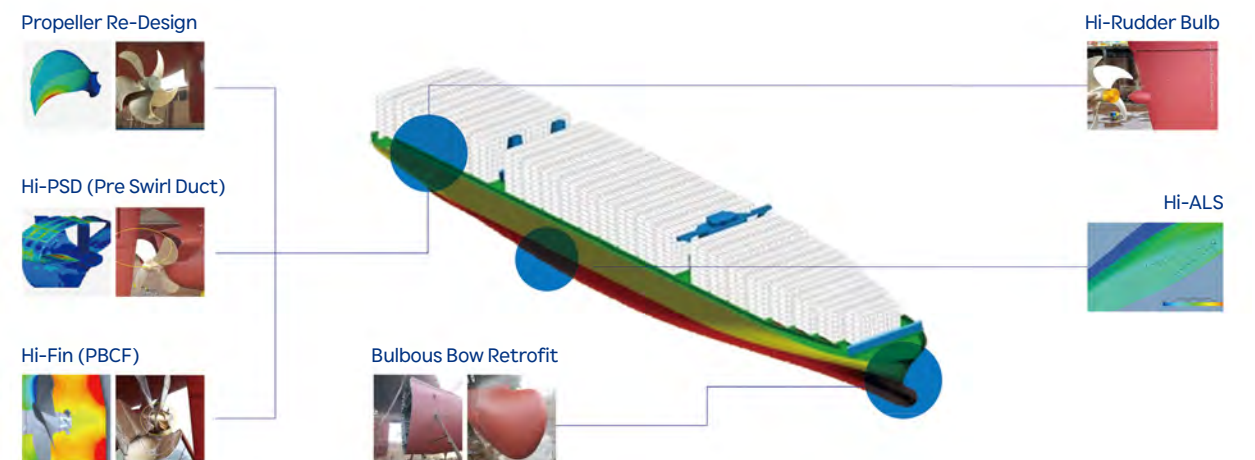

Under the enforcing regulations, HMS could facilitate the ship owners, by providing consulting & analysis to reduce carbon emission for each type of vessel.

HD HMS offers a package of energy saving devices which are integrated into the supplementary Hull lines, making them adaptable for older vessels. Leveraging the extensive expertise of HD Hyundai Group, HD HMS is fully committed to support the enhancement of fleet's performance.

## Dual Fuel Conversion

With rich experiences and advanced technology accumulated from the shipbuilding and marine engine industry over the past decades, HMS, a total solution provider, provides engineering, procurement, and commissioning packages.

HMS does provide a total dual fuel retrofit package that 'JUST FIT YOUR NEEDS' in the way of the most economical and optimized solutions to the Alternative fuel propulsion systems, having appropriate and rich resources from HD Hyundai Group.

### Benefit



Proven reliability through full scale test & most advanced design



Design & documents with full automatic interface within engine system



Proven technology & the world best reference



Qualified marine service provider in the shipping industry

### Hi-Gas

Hi-GAS & Hi-LFSS is an LNG/LPG fuel gas supply system for dual-fuel engines based on high and low-pressure gas supply. The Hi-GAS & Hi-LFSS are designed to be the most optimized for both CAPEX and OPEX.

### Dual Fueled Ship Package

#### Design capability

- Fuel tank
- Fuel gas supply system
- Ship to ship compatibility
- Bunkering & BOG handling
- Safety verification

#### Gas fueled ship package



LNG / LPG Fuel tank deck tank



Fuel supply system



Bunker station



DF Main engine



DF Generator engine



DF Boiler

## LNG Dual Fuel Conversion

HD HMS provides LNG Dual Fuel (DF) conversion services for Everllence Diesel main engines under a strategic MOU.

To meet global decarbonization standards while enhancing the vessel's market competitiveness, LNG continues to play a vital role as a bridge fuel. In this regards, LNG DF conversion can be a reliable and cost-effective strategy.

### Installation LNG Tank

- **Tanker:** IMO Type C Tank of optimized capacity considering fuel consumption of M/E and G/E and voyage route.
- **Container:** IMO Type B or C Tank has been investigated as the most suitable to minimize cargo loss.

### FGSS(Fuel Gas Supply System) Scope

- **Configuration:** HP Pump, Vaporizer for ME-GI engine and LP forcing vaporizer
- **Control System:** Dedicated control system provided for FGSS and fuel tanks, interfaced with existing AMS/ICMS.
- **Auxiliary system:** Includes N2 supply, gas detection, fire-fighting system and ship-shore link (SSL) in compliance with regulations.

### Container (16K TEU Class)

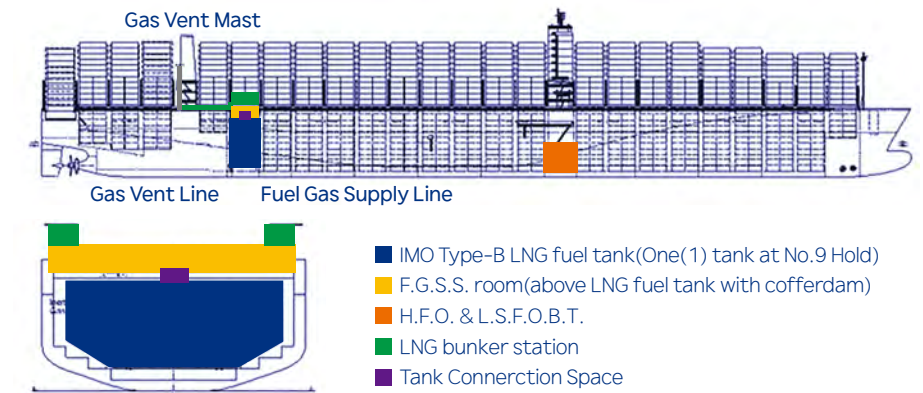

### VLCC (300K DWT Class)

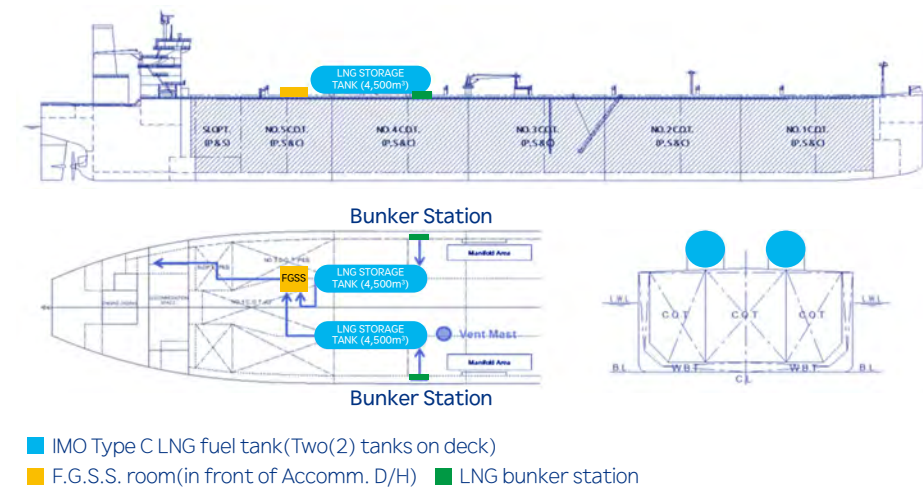

## Methanol Dual Fuel Conversion

HD HMS has carried out FEED engineering for methanol dual fuel conversion with HD Hyundai affiliates and Class KR. At the result of FEED, we have received Approval in Principle for 16K CNTR methanol dual fuel conversion in Dec, 2023.

Target of this AIP is to study and assess the technical feasibility of Ship Conversion Design for Methanol Dual Fuel retrofit. This AIP aims to develop and certify principle design concept of ship conversion for retrofit conventional diesel engine to methanol dual fuel engine.

HMS provides total engineering for alternative fueled vessel conversion including Engine Modification, Fuel Supply system & installation, hull modification & Tank Construction with vessel's efficiency improvement together.

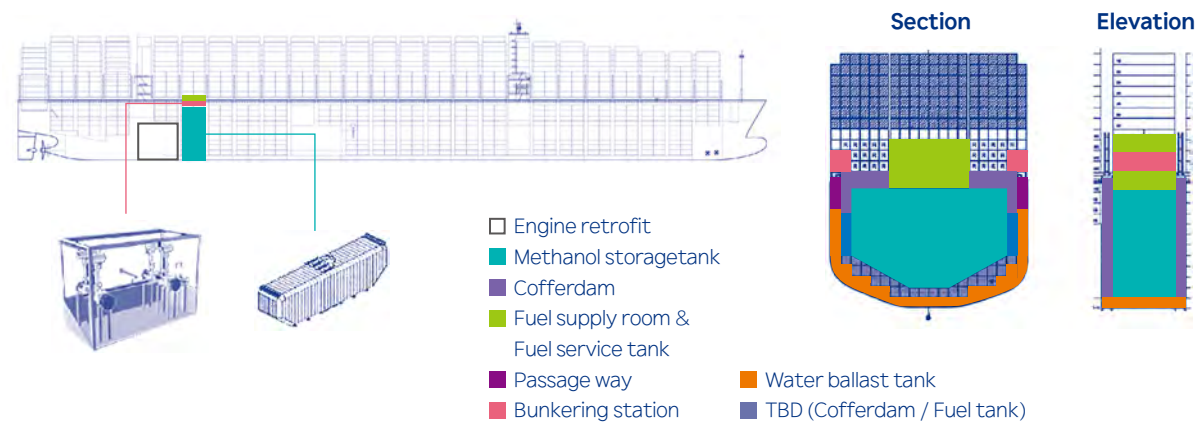

## General Concept - Scope of Work & Supply

Category	Item	Current (as-is)	Retrofit (to-be)
Major Equipment	Main Engine	Everlence ME model	ME-LGIM Conversion
	Generator Engine	HiMSEN model	H32DF-LM Conversion
	LFSS	Nil	<ul style="list-style-type: none"> <li>Methanol Service Tank</li> <li>Methanol Fuel Supply Unit</li> <li>LFSS Control System</li> </ul>
	Methanol Tank	Nil	<ul style="list-style-type: none"> <li>*TBD</li> </ul>
Aux. equipment & bulk material	Nil	<ul style="list-style-type: none"> <li>Aux. Equip:                             <ul style="list-style-type: none"> <li>N2 Generator</li> <li>Gas detection, Fire Fighting Sys. so on</li> </ul> </li> <li>Bulk: Piping, Valves, Elec &amp; Cables, Steel Reinforcement so on</li> </ul>	
Engineering / Class	Nil	<ul style="list-style-type: none"> <li>Basic, Detail, Production</li> <li>HAZID/HAZOP, Analysis</li> <li>Class approval</li> </ul>	
Retrofit & Commissioning	Nil	<ul style="list-style-type: none"> <li>Hull Modification / Installation work</li> <li>General Service, Bulk material &amp; consumables</li> <li>Commissioning / Sea Trial</li> </ul>	
Project Management	-	-	Included

## Shaft Generator

Shaft Generator Drive enables the main engine and propeller to operate at variable speeds whilst maintaining the grid frequency and grid voltage fixed. Unlike conventional in-line shaft generators that require a shaft replacement, HD HMS provides split type shaft generator, which can be retrofitted onto the existing intermediate shaft.

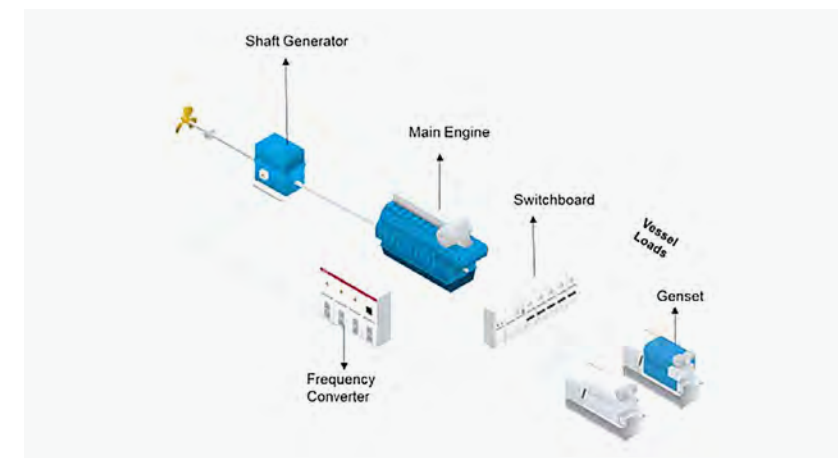
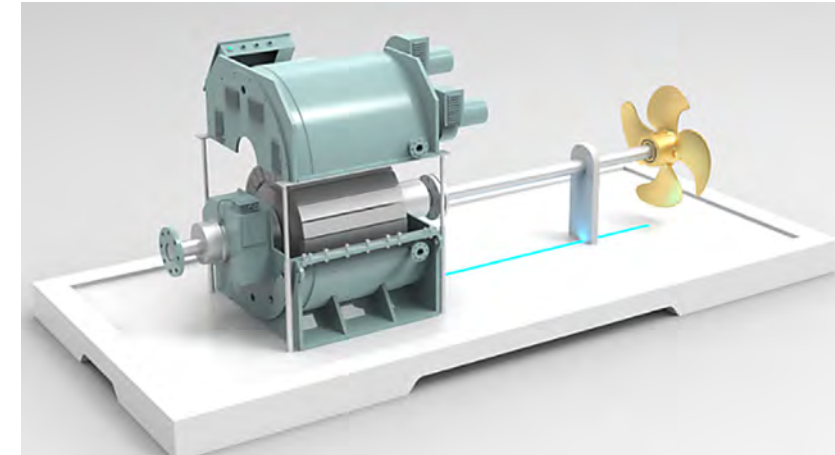

With retrofit-optimized split type shaft generator, Clients can have key benefits as specified below to meet their high electricity demands.

### Benefits

- Reduced Fuel Consumption:** Fuel consumption and emissions are reduced by optimizing operating modes with the shaft generator
- Flexibility:** The shaft generator enables versatile generator operations and secure space efficiency with system flexibility
- Optimized OPEX:** Applying the shaft generator reduces existing generator usage and maintenance, lowering costs
- Low CAPEX:** Cost-effective approach than replacing the entire shaft
- Space Efficiency:** installation within highly constrained spaces, maximizing space efficiency on the existing vessels.

# Engine Part Load Optimization (EPLO)

According to analysis from various Class Societies, a number of vessels will be classified as D (3 years) or E (1 year) within a few years.

A revised SEEMP including the corrective actions for CII reduction shall be submitted to the authorized administration or any organization for verification in accordance with the regulation 28.8 of MARPOL Annex VI.

In the long-term perspective, utilizing carbon-neutral fuels is a fundamental solution. However, there are some critical concerns such as availability of supply for alternative fuels, fuel prices, and bunkering infrastructure. The EEXI and CII regulation can be met by lowering operation speed through the application of Engine Part Load Optimization (EPLO).

EPLO is the solution that matches and optimizes the turbocharger performance required by the engine according to the actual slow operating vessel speed.

The operation of ships with slow steaming have a potential to reduce fuel oil consumption by a part load optimization. Especially, for 2-stroke Everllence-Hyundai & Hyundai Marine engines, not only mechanically controlled (MC Type), also Electronically controlled (ME Type) and equipped ABB Turbocharger shows meaningful outcome.

We would like to summarize the advantage of EPLO as a fuel consumption saving, reducing negative environmental affect & financial benefits. EPLO solution divides 3 variants with expectation of Specific Fuel Oil Consumption.

Variants	#1	#2	#3
SFOC savings (preliminary)	2-3 g/kWh	3.5-4.5 g/kWh	5-6 g/kWh
Derating	85%	85%	85%
Engine Setting	VIT setting	VIT setting	VIT setting
Aux. Blower Setting	>> 2pm lower	>> 4pm lower	>> 8rpm lower
T/C Nozzle Ring	Smaller	Smaller	Smaller
NOx Re-certification	Required	Required	Required
Torsional Vibration	BSR	BSR	BSR
Compressor Wheel	-	Smaller	Smaller
Wall Insert	-	Larger	Larger
Turbine Blade & Shaft	-	-	Smaller
T/C Modification	Slight	Moderate	High
Engine Modification	Slight	Slight	Slight
Effectiveness Moderate	Moderate	Moderate	Highest
Investment Cost	Lowest	Low	Moderate

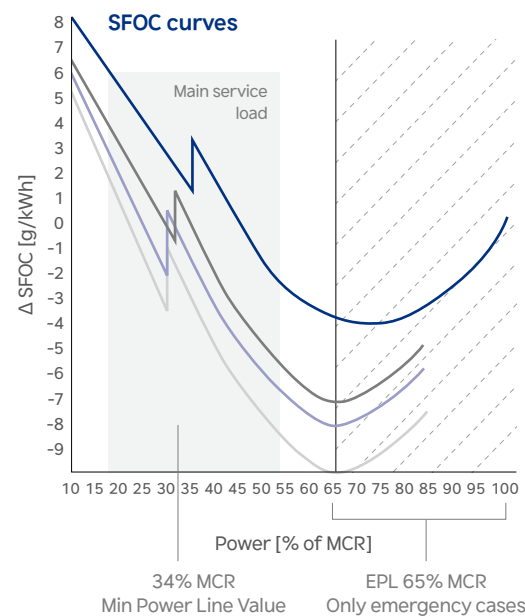

# Alternative Maritime Power (AMP)

World widely, port regulation forces to shut down auxiliary diesel engines to reduce emissions from the vessel. Mainly CARB (California Air Resources Board, USA) has been applied mandatory. Other regions, including the EU and China, will be applied soon. AMP would bring the most promising effects for air pollution and meet the mandatory requirement at the port. HMS is a turnkey provider for AMP retrofit and provides AMP retrofit solutions for all kinds of vessel, including as following.

## Vessel Type

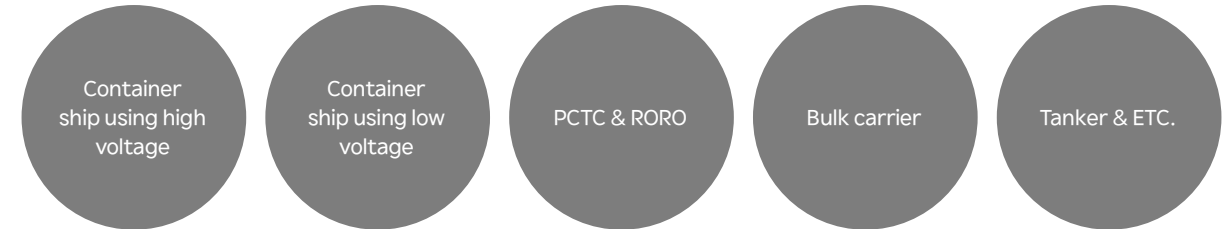

HMS can customize engineering with references for retrofit items, own equipment including switchboard, cooperation with cable reel maker and various experience in installation even sailing and optimal engine and its auxiliary equipment performance, thus minimizing our clients' CAPEX and OPEX.

## Construction Process For Container & Bulk Carrier

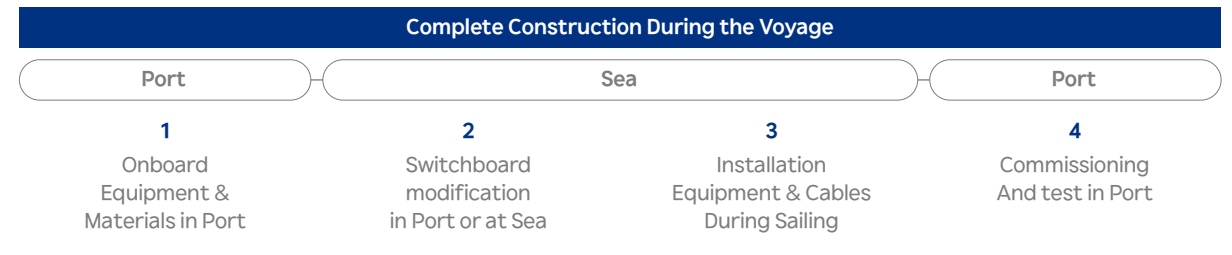

## Construction Process For PCTC & Tanker

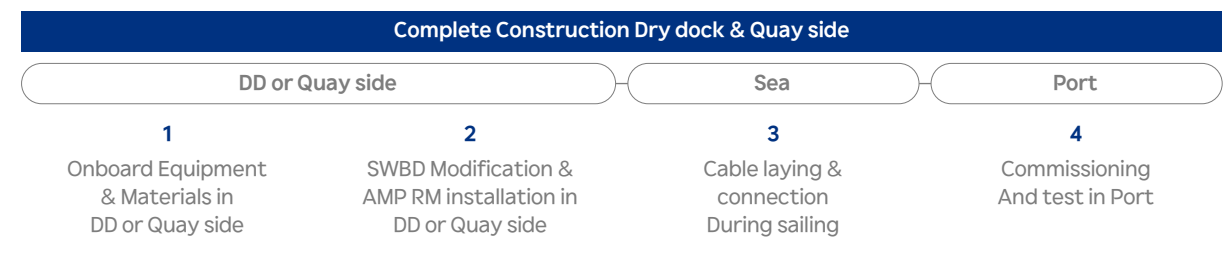

# LNGC Re-Liquefaction Plant Retrofit

Re-liquefaction technology is one of the solutions for DFDE LNGCs to manage BOG and reduce emissions. Turbo-brayton technology uses a closed-loop refrigeration cycle to cool the BOG and re-liquefy the gas, which can be used as fuel on board or sold as LNG. With Re-liquefaction plant, the burden of cargo taxes and cargo loss can be minimized. Furthermore, if the BOR rate is more severe, the ROI is expected to be much faster, allowing shorter payback period and complying with GHG regulations.

## Re-Liquefaction Plant

### Turbo-Brayton System



Image Source : "Air Liquide"

- Indirect liquefying BOG
- Refrigerant : N2
- Suppression of BOG



Image Source : "CRYO STAR"

- Using sub-cooled LNG
- Major Equipment
  - 1) Motor-Turbo Compressor-Expander
  - 2) Cold Box

## General Arrangement

Compared with newbuilding, the Turbo-Brayton system is suitable for retrofit vessels since this system can be replaced anywhere and has a low impact on an existing ship's cargo handling system. Generally, the Turbo-Brayton system can be applied to both Moss and Membrane type LNGC, and it is a built-in port or starboard side with an electric cabinet room.

### Side View

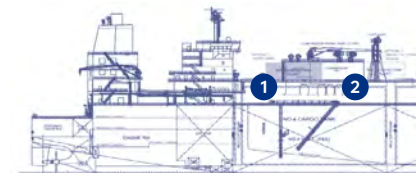

### Top View



#### Reliquefaction Plant

- Option 1. Port Side
- Option 2. Near to Comp. Room

## Reference List

No	Owner	Type of vessel	Type of retrofit	D/D
1		160K LNG	EPIC	2024
2		162K LNG	EPIC	2024
3		162K LNG	EPIC	2024
4	EUROPE	170K LNG	EPIC	2024
5		170K LNG	EPIC	2025
6		152K LNG	EPIC	2025
7		160K LNG	EPIC	2026
8	U.S.A	160K LNG	EPIC	2026
9		160K LNG	EPIC	2027
10	EUROPE	162K LNG	EIC	2025
11		162K LNG	EIC	2025

# LNGC To FSRU Conversion

## General Arrangement

Compared to the Newbuild FSRU, FSRU Conversion based on LNGC for Moss and Membrane types typically has less lead time and cost. It simply requires the installation of Regas modules and DF modules. The Regas module is usually built as a separate module or compartment and retrofitted onto the LNGC in a shipyard to minimize time.

### Moss LNGC

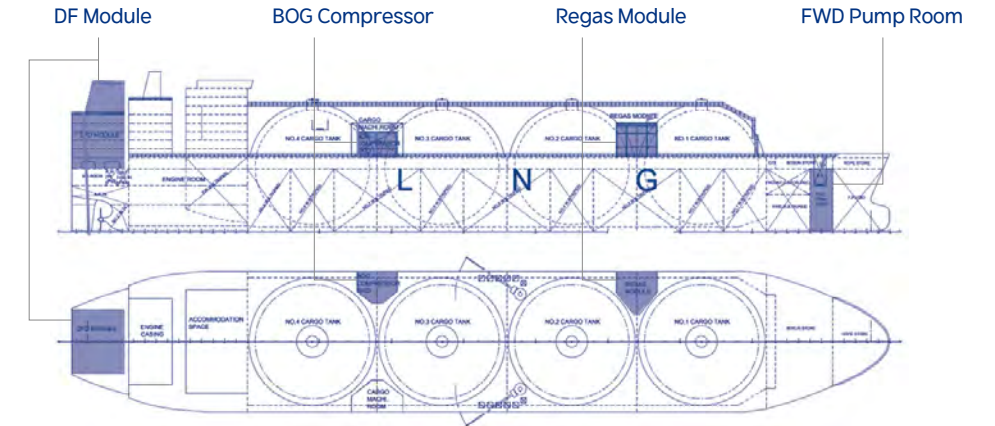

### Membrane LNGC

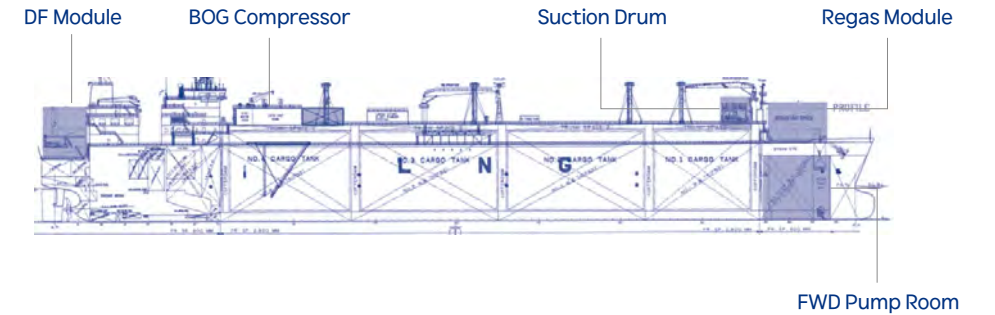

## Hi-ReGAS

HD Hyundai developed own Re-gasification system which changes LNG from liquid to gaseous state. With an advantage of power saving by optimized booster pump figuration, it is safe and reliable by non-flammable heating medium.

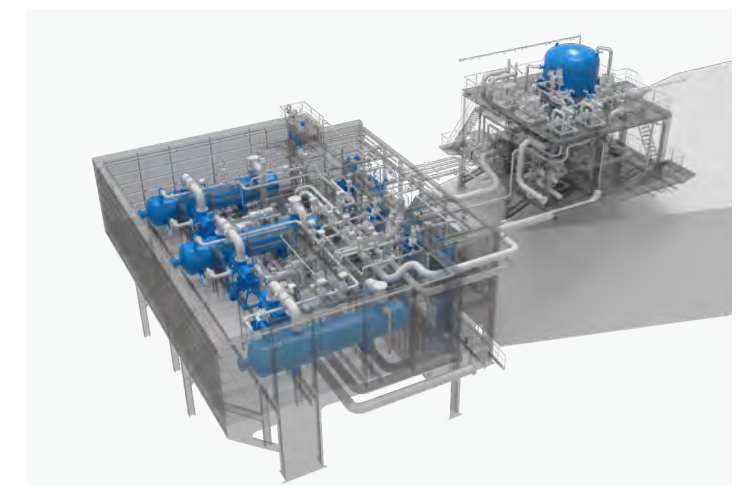

## MSS(Methane Slip Solution)

As regulations such as the IMO GHG Mid-Term Measures, the EU ETS, and FuelEU Maritime become stricter, ships are no longer judged only on CO<sub>2</sub>, SO<sub>x</sub>, and NO<sub>x</sub> emissions. Methane (CH<sub>4</sub>) emissions are also being closely controlled. Because of this, shipowners are looking for practical ways to reduce methane slip.

\* **Methane slip:** Release of unburnt methane into atmosphere during the combustion of LNG-fueled engines.

### Methane Slip Solution for HiMSEN Engines

#### • Hardware updates:

We focus on minimizing crevice volume, the area where unburnt methane are accumulated.

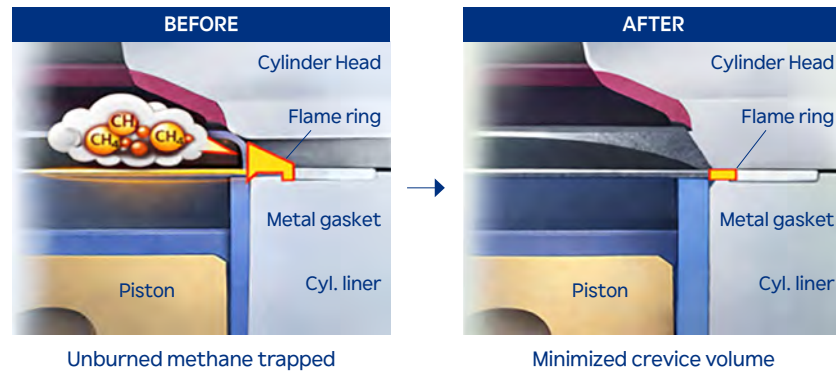

#### • Software updates:

Combination of CCO (Cylinder Cut-Off), MPI(Multi-Pilot Injection), AFR(Air Fuel Ratio), waste gate valve control minimize unburned methane.

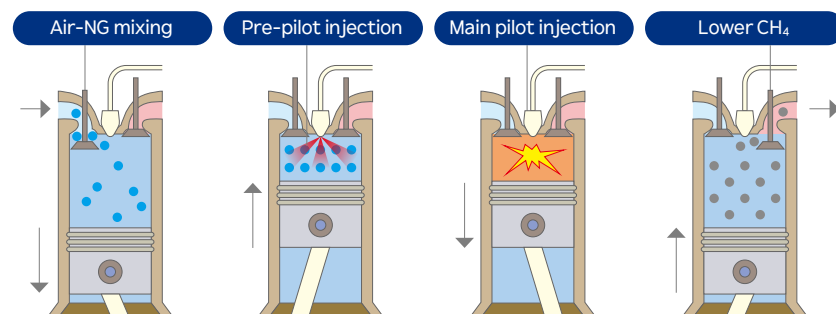
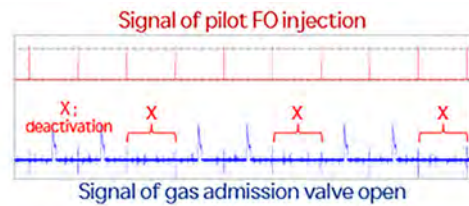

### Benefits

- Regulatory Compliance together with IMO Nox Tier II
- Methane Slip Reduction
- Improved fuel efficiency

## iCER(intelligent Control by Exhaust Recycling)

iCER is an exhaust gas recirculation (EGR) based system designed to minimize methane slip for WinGD XDF engines.

When iCER is applied, the operating window area of air fuel ratio for combustion is wider and Maximum cylinder pressure is reduced by recirculating the exhaust gas.

### Benefits of iCER

- Savings on both fuel gas and oil consumption
  - : 3% less energy consumption in gas mode
  - : 5% less fuel consumption in diesel mode (Tier III Compliance)
- Up to 50% less methane slip emission
- No DCC(Dynamic Combustion Control) activation



## VCR(Variable Compression Ratio)

VCR is variable compression ratio which can be installed with iCER. VCR system shifts the position of the piston at top dead center, so adjusts compression ratio.

With VCR system, EGR rate is increased at part and low load, so methane slip is reduced accordingly.

#### • Compression Ratio (CR)

- **In diesel Mode:** CR can be increased to a similar level as on a conventional diesel engine
- **In Gas Mode:** CR can be increased in part load to utilize 'combustion margin'

# OceanWise

OceanWise solution has been started with the idea of Ocean Transformation from CES 2023, to use the scattered data from the vessel and ocean to achieve more insight and contribute to carbon reduction that will be beneficial for both charterers and ship owners. Our main objective is to use any form of data from Noon Report or Data Collecting System to provide accurate vessel performance models and use these models for CII Monitoring, Simulation, Voyage Optimization, SEEMP III Guidance, and more. With our high accurate models we have integrated A.I technology to create value that evolves together with the given and public data. This solution is just our first step into the Ocean Transformation journey and the OceanWise solution can expand this MetaOcean Database into something much bigger and more customized.

### Essential Functions:

1. Vessel Performance Modeling for CII Monitoring & Prediction
2. Simulation for Vessel Management using Port Congestion Data
3. Advanced Voyage Optimization for increase in Fuel Efficiency.
4. SEEMP Part III Guidance Report.

### And OceanWise is:

1. Hardware Free - High Accessibility
2. Leveraging A.I Technology + World Leading Ship Building Knowhow
3. Simple Input – Significant Output

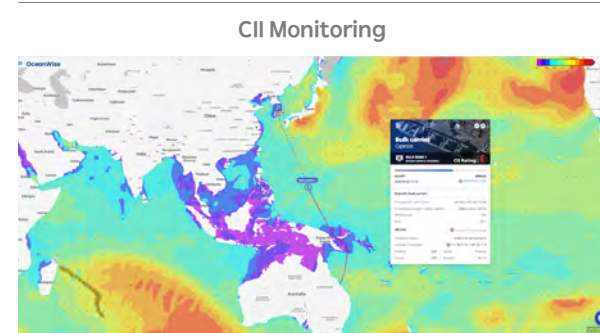

CII Monitoring  
AI model accuracy 95% to monitor vessel performance with CII rating

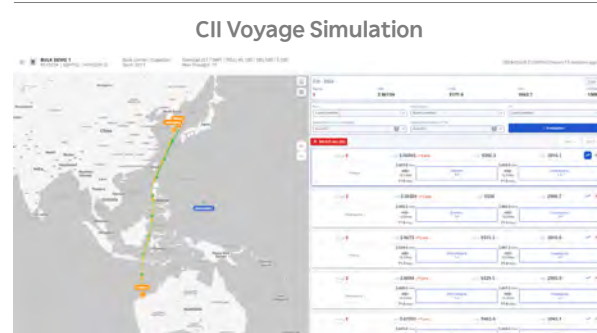

CII Voyage Simulation  
Using Accurate model to simulate voyages to find most suitable port for vessel and understand future carbon emission

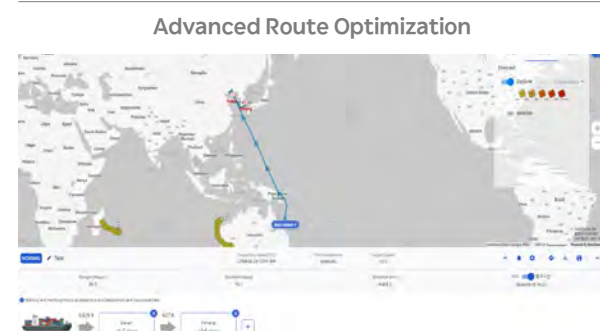

Advanced Route Optimization  
Integrating Port Congestion with Route Optimization, Weather Information for most cost-efficient and safe route

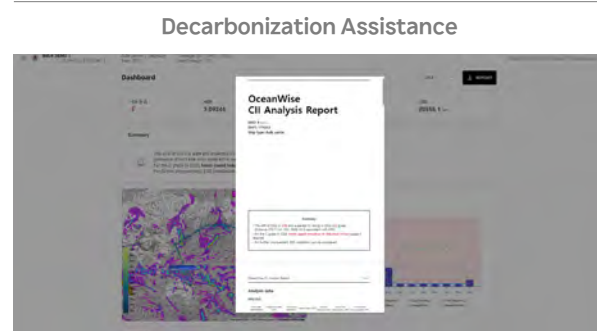

Decarbonization Assistance  
SEEMP Dashboard to understand vessel status and to provide SEEMP III Guidance for vessels that does not meet required CII Rating

## Experience the Ultimate Emission Reduction and Fuel Efficiency with the Autonomous Navigation Solution from OceanWise

### Enhanced AI performance with OceanWise provides:

1. MetaOcean Database AI Models accurately predict ship performance across various sea conditions.
2. Optimal Route Planning benefits with sophisticated routing algorithms for efficient navigations.

### Precision Control with HiNAS Control Systems provides:

HiNAS Cruise Control ensures precise adherence to planned routes and minimize resistance.

By integrating OceanWise's routing plans and HiNAS's system control, we enable efficient, fuel-saving operations. The process is based on MetaOcean data cloud, allowing for ongoing assessment and enhancement through advanced data learning and technology improvement. Fuel savings of up to 10% can be expected with OceanWise optimal routing, up to 15% when combined with HiNAS, and we are continuously accumulating valid and reliable cases.

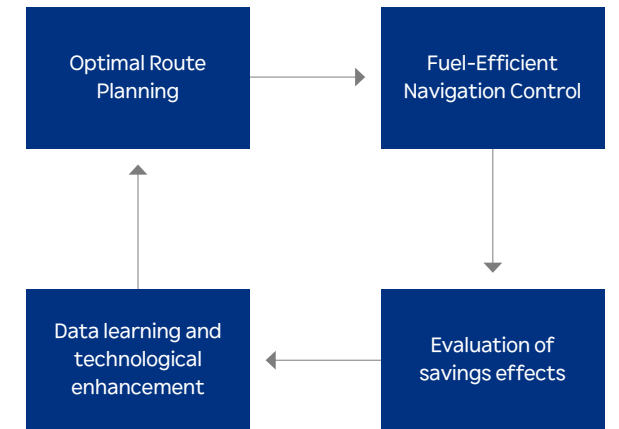

## HiNAS by Avikus (Hyundai intelligent Navigation Assistance System)



NAS Navigation is a computer vision and AI-based system that assist safe navigation by displaying detected ships and navigation information in AR images. Also, it enables to overcome the limitation of conventional sensors of the ship through sensor fusion technology.

### Key feature

- Vision sensing**
  1. Deep learning-based automatic object detection
  2. AI-supported camera-based lookout assistance
- Sensor fusion**
  1. Sensor fusion-based situational awareness
  2. Radar, AIS and camera sensor fusion for higher accuracy and robustness
- AR visualization**
  1. Augmented Reality visualization
  2. Intuitive navigation assistance and collision & grounding alarm
- NAS Control**

Autonomous navigation assistant system that has the functions of route optimization, route tracking, and collision avoidance

# Integrated Smartship Solution (ISS)

Integrated Smartship Solution (ISS) helps to reduce operational costs during voyages. It estimates the optimal voyage considering the weather forecasting, operational condition, voyage schedule, etc. Clients can make a better decision by comparing the current status of their voyage and the optimal voyage recommended by ISS. ISS tracks the client's vessel's energy flow and has an intuitive understanding through the machinery management module. Reports such as noon, voyage, MRV and DCS can be generated by the solution to assist the user's document work.



## Features

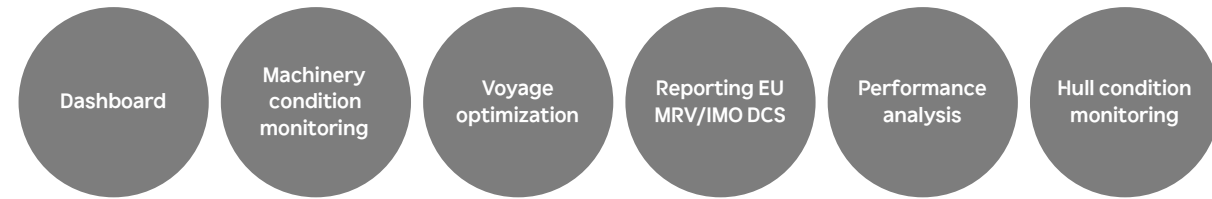

# What is Hi4S ?

Hi4S (Hyundai intelligent Smart Solution Service System) provides the one-stop solution through 24/7 S.M.A.R.T. care service system. Our best skilled experts monitor and analyze all the collected data from your fleet/ships to provide what you need to know for optimal operation. You can easily access Hi4S web service to monitor and operate your fleet at your convenience.



## DI Report (Digital Insight Report)

Experts analyze the operation data of voyage and machineries collected from onboard and provide DI Report to clients. It also provides essential information such as warranty service information and the latest service news.

- Voyage analysis with potential fuel savings
- Engine performance analysis and load diagram



## Engine Analysis Report

It shows engine performance analysis at a glance, precisely quantifies optimization potential in a systematic way, and offers recommendations for adjusting and maintaining marine engines.

- Optimized engine performance and fuel efficiency
- Less maintenance costs
- Increased reliability



# Hi-Secure

Hi-Secure is an advanced cyber resilience solution engineered to meet the rigorous demands of the modern maritime industry. It is a packaged solution that provides an integrated IT/OT operational platform composed of NMS (Network Monitoring System), firewalls, and L3 switches, delivering a consistent and unified security layer for shipboard networks. To strengthen a defense-in-depth architecture, additional capabilities can be integrated as needed.

### • Alignment with IACS UR E26 & E27:

Hi-Secure is designed to meet the latest cyber resilience requirements for onboard systems (E27), while enabling ship-level security functions and architecture in line with IACS UR E26.

### • Maritime-Grade Durability (IACS UR E10):

Built on hardware certified for IACS UR E10, ensuring stable operation under harsh maritime conditions, including vibration, humidity, and electromagnetic interference. Designed with usability at its core, Hi-Secure enables not only IT professionals but also onboard crew and shore-based operators to efficiently manage and secure complex shipboard networks.



## Optional Services (Tailored to Your Needs)

- **HA (High Availability):** Ensures continuous system operation through redundancy and failover mechanisms.
- **DPI (Deep Packet Inspection):** Provides advanced traffic analysis by inspecting OT System's packet payloads.
- **NAC (Network Access Control):** Controls and enforces device access to the network based on identity, policy, and security posture.
- **SIEM (Security Information and Event Management):** Collects and analyzes security logs for real-time monitoring.
- **SOAR (Security Orchestration):** Automates security workflows and incident response processes to improve efficiency.
- **XDR (Extended Detection and Response):** Delivers integrated threat detection and response across endpoints, networks, and systems.
- **Shore-based SOC Services:** Provides centralized monitoring, threat analysis, and incident response support.
- **Cyber Security Resilience Program (CSRP) Support:** Supports the shipowner's CSRP, enabling lifecycle-based cybersecurity operations.

# Console, GCP, BNWAS

All the main equipments can be monitored and controlled necessary for the operation of the ship.

- BCC (Bridge Control Console)
- ECC (Engine Control Console)
- CCC (Cargo Control Console)
- BWC (Bridge Wing Console)
- GCP (Group Control Panel): Navigation & Signal Light Control
- BNWAS (Bridge Navigational Watch Alarm System): Detecting Operator Disabilities to Prevent Marine Accident



# Integrated Control And Monitoring System (ICMS)

ACONIS (Advanced Control and Integrated System) is a competent and proven solution for marine applications such as ICMS (Integrated Control and Monitoring System), cargo handling system, BWTS, and SCR (Selective Catalytic Reduction).

HiCONIS (Hyundai intelligent Control and Integrated System) is an Integrated Automation System (IAS) that supports multi-functional alarm monitoring, data acquisition, and control functions of ships. It is adaptable for all ships, e.g., LNG, LNG-FSRU, drillship, drilling rigs, container ships, bulk carriers, cruise vessels, reefers, and other special purpose vessels.

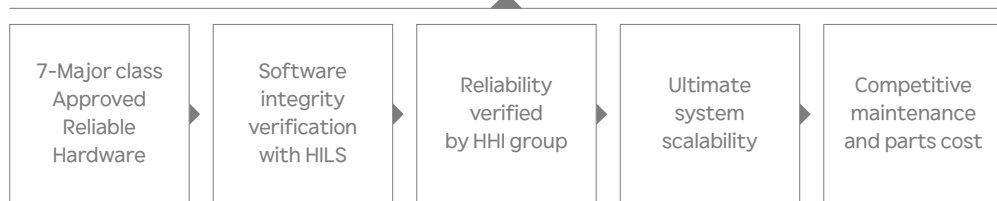

Items	Specification
System Capacity	<ul style="list-style-type: none"> <li>• 1,152,000 Total Tags</li> <li>• 256 Stations</li> </ul>
Server Type	<ul style="list-style-type: none"> <li>• Multi-Server</li> <li>• Historian</li> </ul>
HMI	<ul style="list-style-type: none"> <li>• Layer/Script/Zoom In-Out</li> <li>• Multi-Display</li> </ul>
Redundancy	<ul style="list-style-type: none"> <li>• Dual Network(Workstation, Processor)</li> <li>• Dual Processor(MPM)</li> </ul>
Programming Language	<ul style="list-style-type: none"> <li>• IEC61131-3 standard 5 languages</li> <li>• Standard Function Block</li> </ul>
Database Update	<ul style="list-style-type: none"> <li>• Initial/Online Download</li> </ul>
Simulation	<ul style="list-style-type: none"> <li>• Process/Control Logic Simulation (Online)</li> </ul>

# Shaft Generator Package

HMS provides optimal Shaft Generator solution which is customized as per customer's requirement, operating concept and installation space according to various vessel type.

With our knowledge & experience of ship operation and automation system as a member of HD Hyundai Group, we are confident to provide best solution as a qualified system integrator based on collaboration between HD KSOE(HD Hyundai Group's R&D specialized company) and HDE(Electrical equipment manufacturer).

Our shaft generator package provides various outputs from 0.5 to 5MW. In addition to supplying induction type shaft generators, which are traditional type, we mainly supply Permanent Magnet type shaft generators that have recently attracted attention for their efficient and compact size compared to induction type.

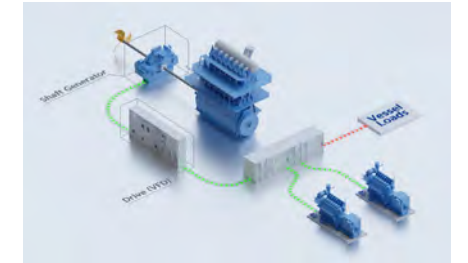
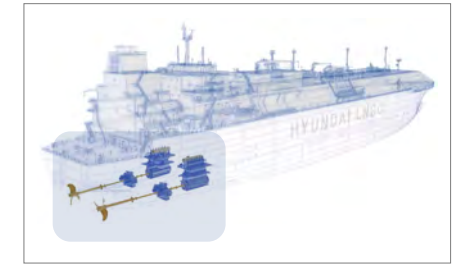

Items	Specification
Mode	• PTO / PTI / PTH Mode
Machinery type	• Induction / Permanent Magnet
Power capacity	• 0.5 ~ 5 MW
System Efficiency	• Over 90 % (Depends on configuration)
Vessel type	• All kinds of vessels (LPGC, LNGC, CNTR, TNKR, PCTC, etc.)
Battery solution	• O (Possible to supply)
VFD topology	• AFE (Active Front End)

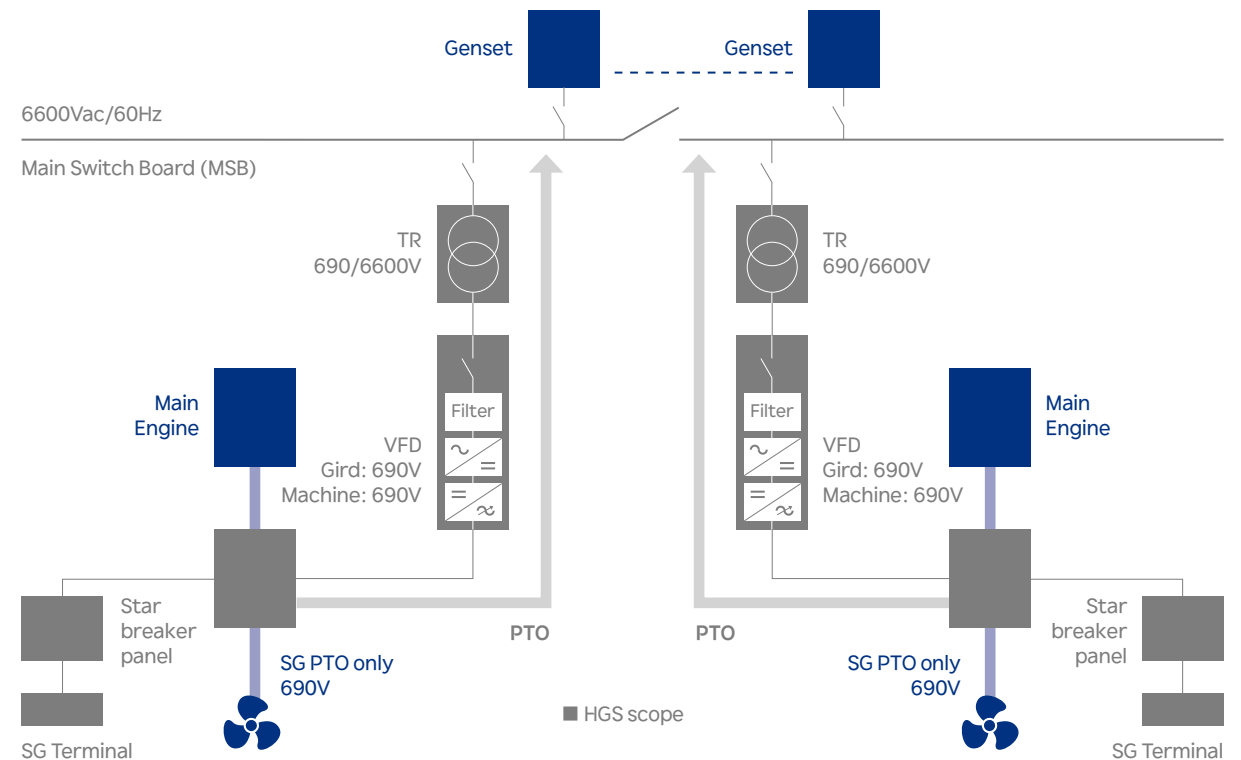

## SmartCare

SmartCare is our service brand for all HD Hyundai Group products. We offer worldwide, 24/7 service 365 days a year. SmartCare provides customer warranty service for HD Hyundai Group vessels, engines, machinery, power & automation control equipment, and eco-friendly products.

SmartCare eliminates unsafe factors and risks in products through a warranty, and prioritizes the safe and optimal operation of vessels.

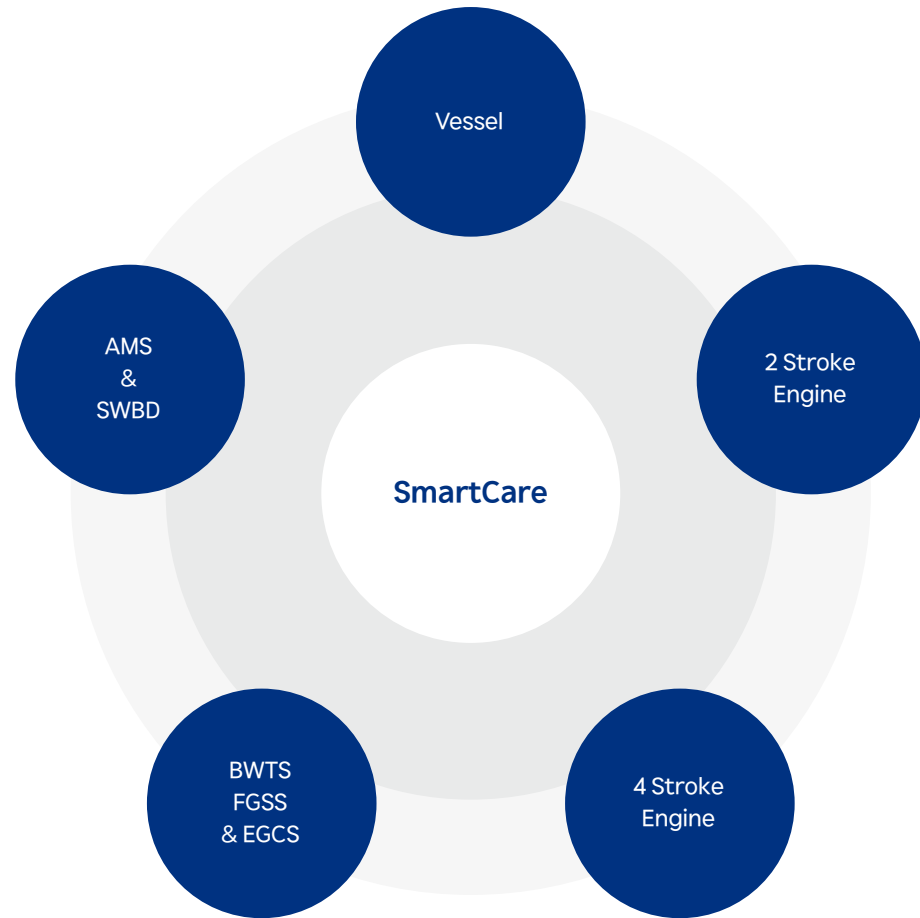

## Solution Orientation

SmartCare offers powerful and quick way after-sales service through a HD Hyundai Group global network. In order to repay customers with the best quality, SmartCare reviews and provides feedback from the various lessons learned, which it turns into big data to improve the standards of vessels and products built by HD Hyundai Group and to carry out activities to prevent the recurrence.

## Life Time Service

SmartCare is dedicated to offering comprehensive customer care throughout the vessel's entire life time. In order to respond to customer's demands after the guarantee period, SmartCare provides a 'Post Warranty Service' to the customers. Using our 'Post Warranty Service' is the most convenient way to ensure that your vessel will meet the safe and optimal operation. SmartCare 'Post Warranty Service' is available for 24/7 from our HQ, Global branches and online.



## Procedure

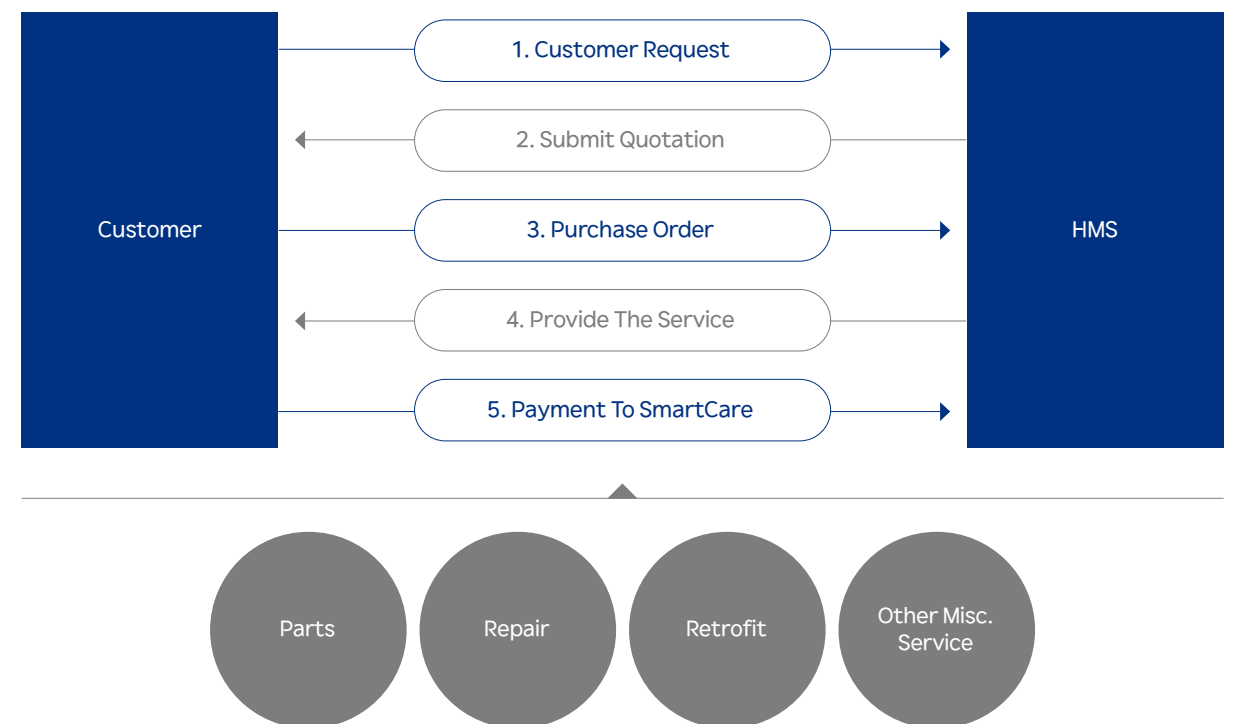

## Bunkering Service

HD Hyundai Marine Solution supplies qualified marine fuels for global vessels throughout the Korean ports in association with one of the top oil refinery companies in Korea, HD Hyundai Oilbank. HD Hyundai Marine Solution supplies ISO 8217:2010 and MARPOL Annex VI guaranteed marine fuels, through experienced and safe barging operation.

Not only ensuring our position in bunkering business in South Korea, we also expanded our business to Singapore to grow as a global bunker trading company. The bunkering experiences to new-built vessels within HD HHI group has led us to extend our service scope to global operating vessels. We are developing ourselves to serve our customer globally and building long-lasting relationships continuously.

As one of the first movers in the supply of alternative fuels, HMS continues comprehensive preparation to reduce emissions of carbon dioxide and other greenhouse gases and we aims to sail together in net-zero with our clients.

Since 2009



Clients **200+**

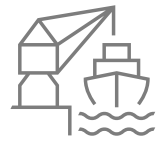

New-Builds **400+**



Ships **11,000+**



## Alternative Fuels

As HMS well recognize the importance of alternative fuels in shipping, we are seeking to diversify the energy mix to reduce reliance on conventional fuels. Diversification of the fuels not only benefits the environment but also enhances energy sustainability.

HMS provides marine fuels certified by ISCC-EU, and is working with HD Hyundai affiliates and global shipping companies to develop our business portfolio toward various types of alternative marine energies.

We are taking the initiative in Eco -friendly fuels including biofuels, methanol, ammonia, and hydrogen while following stricter international regulations and global trends. Starting with the trial of a biofuel bunker, HMS is now ready for methanol bunkering service on ships as well. We also launch 'UREA' for vessels which ensure a high purity with reasonable price.

We are actively involving in promoting environmental sustainability. We devise the best possible ways to enhance the experience in vessels' operation at every stage of vessels' entire life span.



### Fuel Types Supplied



#### Low Sulfur Fuel Oil

Environmentally friendly marine fuel with sulfur content below 0.5%



#### High Sulfur Fuel Oil

High sulfur fuel oil with sulfur content below 3.5%



#### Low Sulfur Marine Gas Oil

Environmentally friendly marine gas oil with sulfur content below 0.1%



#### B30 Bio Marine Fuel

Low-carbon, environmentally friendly, bio marine fuel



#### B100 Bio Marine Fuel

Low-carbon, environmentally friendly, bio marine fuel



#### Methanol

Low-carbon next-generation marine fuel

# Power Plant

## Total Care Solution

HMS is the specialized total service provider of power plant covering warranty, O&M, spare parts, engineering, fuel conversion and training. For engine based power plants, HMS have provided its power plant service for over 1,700 units, a total of 5,900MW in 59 countries.

## Full O&M Service

- Provides daily, weekly, and monthly operation reports by professional engineers.
- Execute proper maintenance, whether scheduled or unscheduled.
- Managing all kinds of risks and decisions at the right time.

## Work Scope



Total Install Capacity  
**5.9GW**

In-Service  
**4.5GW**

## Reference

Colombia, Termonorte	Africa, Cabo Verde	Angola, Prodel
20H35/40DFV x 10 Sets	9H21/32 x 2 Sets	9H21/32 x 104 Sets
5 Years Full O&M Contract from December 2018	7 Years Full O&M Contract from March 2020	4 Years O&M + Supervision from September 2013

## Work Scope By Service

○ Included × Not Included ◌ Optional

Work Scope	PO Based Service	LTPA	LTSA	O&M
OEM Spare Part Supply	○	○	○	○
OEM Spare Part Supply in Stock	×	○	○	○
Technical Support	○	○	○	○
Supervision for Scheduled Maintenance	◌	◌	○	○
Execution for Scheduled Maintenance	×	×	×	○
Plant Operation	×	×	×	○
Unscheduled Maintenance	×	×	×	○
Lube Oil Supply & Service	×	×	×	◌
Guarantee for Reliability	×	×	×	◌
Guarantee for Output	×	×	×	◌

Work scope is flexible and can be customized upon client's demand. We offer Long Term Part Agreements (LTPA) and Long Term Service Agreements (LTSA). Both agreements include OEM Spare Part supply in stock and Technical Support through regional service hub worldwide. LTSA's are suitable for engine with a minimum of 24K and a maximum of 48K running hours. We recommend contract period from 3 to 6 years to serve best efficiency.

## Best Timing To Consider LTSA

1. At the start and end of power plant construction
2. At the end of the warranty period
3. Before Major Overhaul Period

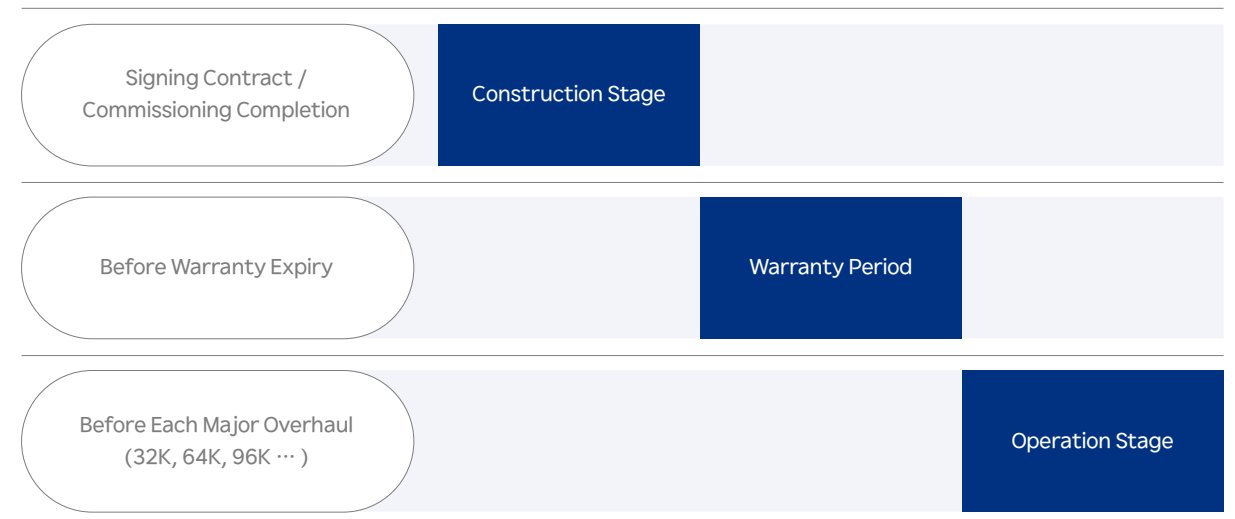

# Global Academy

HMS Global Academy offers tailored programs to deliver expertise to ship and power plant engineers. We provide training services on 4-stroke HiMSEN engines, electrical facilities, and environmental products.

Various manners such as theoretical lecture, simulators, and hands-on practice are employed for effective training. We promise that you will learn essential items about our products when you complete the Global Academy programs.

HMS can conduct training at its Global Academy and onboard or on-site, regardless of the location of the training venue. As for theoretical training, we can provide trainees with online training that they can access anywhere. Since online training also offers real-time Q&A sessions, there is no difference between online and in-person training in trainees' comprehension of the training material.

## Training Method

HMS Global Academy goes beyond theoretical education by providing high-quality training utilizing advanced simulators and equipment. Based on this foundation, we offer practical hands-on training in disassembly and assembly for various engine parts, as well as on-board and site training.

## Main Training Course

- HiMSEN Diesel
- HiMSEN DF
- Main Engine
- Stationary Power Plant Major Aux. Facility
- BWTS
- NoNOx SCR
- SOx Scrubber
- Turbocharger
- Alarm Monitoring System (ACONiS & HiCONiS)
- Switch Board
- Circuit Breaker
- Hi-VDR



## Facility

Lecture hall

Practice Center(Busan)

Practice Center(Ulsan)

## Equipment

6H32/40(DF) HiMSEN

5H21/32 HiMSEN

DF engine simulator

ACONiS Simulator

MV/LV Switch Board



Training Courses

16

Educators

16

Trainees/Year

500+



Everywhere, we are there



# HD Hyundai Marine Solution Tech



Founded in  
APRIL 1, 2022



Employee  
130+ People



6 Branch Office  
(Rotterdam, Singapore, Dubai,  
China, Panama, Athens)

We are moving towards becoming the world's best technology solutions company that leads the sustainable future of the maritime industry.

HD Hyundai Marine Solution Tech, a subsidiary of HD Hyundai Marine Solution, was established in April 2022 with the purpose of providing professional technical services related to HD Hyundai Group's ships, engine machinery, and electrical and electronic businesses.

Since its establishment, the company has stabilized its business faster than initially planned and secured top talent, establishing itself as a specialized service provider. In addition, Based on the expertise of highly skilled engineers in the field of marine / engine machinery / electrical and electronic systems, we quickly provide technical sales support and technical support for the maintenance and repair of customers' ships.

HD Hyundai Marine Solution Tech has established service network bases in major ports such as Rotterdam, Singapore, Dubai, China, and Panama to expand the provision of real-time services that can respond to any region of the world, and aims to grow as a technology leader by developing customized services according to the diverse needs of customers.



At the request of our customers, HD Hyundai Marine Solution Tech's expert technicians provide fully customized technical services for all vessels and equipments supplied by HD Hyundai Group at any time, anywhere in the world, depending on the condition of the equipment.

Proactive Maintenance and Planned Maintenance System by specialized engineers and skilled technicians will keep your vessel in optimal condition. This ultimately enables stable vessel operation by reducing downtime and preventing off-hire.

HD Hyundai Marine Solution Tech operates various businesses such as Engine Service, Electric/Control Service, Dry-Dock Maintenance Service, Propeller & Rudder Package Service, and Workshop Recondition Service to build customer trust.

- |  |   |
|--|---|
| <p>1 On Board(Site) Service</p>                            | <ul style="list-style-type: none"> <li>• Main / HiMSEN Engine Service (Including Gas/DF)</li> <li>• MSBD / AMS / PMS / VCB / ACB / GENERATOR</li> <li>• BWTS / Thruster / COP(T) / SCR / Scrubber</li> <li>• Purifier / Oil Separator / Others</li> </ul> |
| <p>2 Dry-Dock Maintenance Service</p>                      | <ul style="list-style-type: none"> <li>• Main Engine / HiMSEN Engine / Thruster Overhaul</li> <li>• Re-Engine Service / DF Retrofit</li> <li>• MSBD / AMS / PMS / VCB / ACB / Generator</li> <li>• BWTS / COP(T) / SCR / Scrubber</li> </ul>              |
| <p>3 Workshop Recondition Service</p>                      | <ul style="list-style-type: none"> <li>• Main Engine Reconditioning</li> <li>• HiMSEN Engine Reconditioning</li> <li>• VCB Reconditioning</li> <li>• HiMAP Reconditioning</li> </ul>  |
| <p>4 Propeller &amp; Rudder Package Service and Others</p> | <ul style="list-style-type: none"> <li>• Propeller Package</li> <li>• Rudder Package</li> <li>• Refrigerant Gas Retrofit in HVAC Sys. as per the EU F-gas regulation(517/2014)</li> </ul>   |

# Singapore Logistics Hub

In 2026, HMS established a logistics hub in Singapore, strategically positioned at the center of global maritime routes. As many customer vessels pass through Singapore or call at nearby ports, this location enables HMS to provide faster and more efficient support. The hub is located near key ports such as PSA Port, Tuas Port, and Malaysia's PTP Port—major hubs where global vessels frequently call.



Founded in April, 2026



10,000+ Critical Parts

## Location

6 Pioneer Walk,  
Singapore 627751  
(Located near Tuas Mega Port and Pasir Panjang Port)

## Area

15,504m<sup>2</sup>

## Founded in

April, 2026

## Inventory Operations

A key strength of the Global Hub :

- 10,000+ critical spare parts stocked
- Inventory planned based on a 5-Year forecast
- High-demand parts are always available for immediate supply



## Expanded Global Network

With dual hubs in Busan and Singapore, HMS is significantly strengthening its supply network.

- Connected to 200+ global shipping lines
- Network coverage of 600+ ports worldwide
- Combined container throughput of approx. 70 million TEU annually

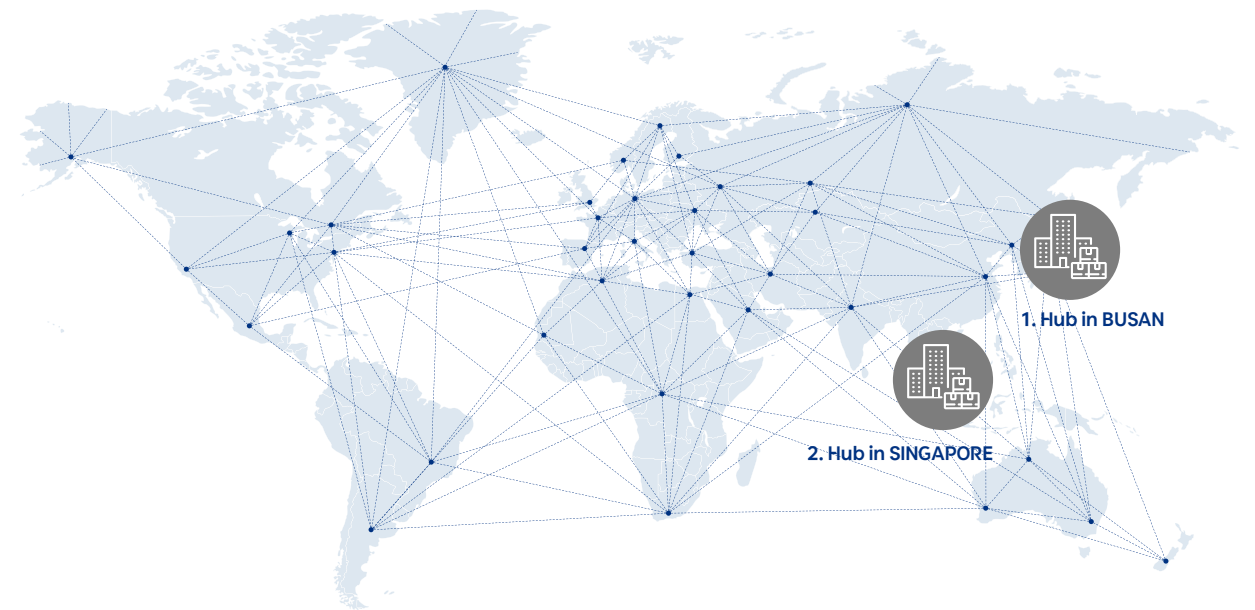

## Customer Value

- 1 Optimized Transshipment & Faster Lead Times**  
 As a global transshipment hub, Singapore enables efficient cargo movement and regional distribution. Combined with its close proximity to major ports, HMS can deliver required parts more quickly, reducing overall lead times while improving logistics efficiency.
- 2 Proactive Inventory Strategy**  
 Long lead-time items are secured in advance. A balanced mix of imported and locally sourced materials ensures both supply stability and operational flexibility.
- 3 Customized Support Services**  
 Tailored storage and operational solutions are provided based on customer needs, including dedicated warehouse space and customized supply programs.

# HD HMS Europe

## Work Scope

- Technical Service (Maintenance, Reconditioning and others)
- Spare parts sales
- Fleet Demand Survey Spares & Service
- Long Term Service Agreement
- Warranty & Lifetime Service
- Retrofit Conversion
- Training Service

## Warehouse

Area  
3,100m<sup>2</sup>

## Inventory

- Aux. Engine Parts (Himsen Engine)
- Main Engine Parts (MAN, WinGD)
- Total 10,000 Types of Spare parts
- Stock Amount Approx. USD 40M(in 2023)

## Branch Offices

- Athens (Greece)
- Hamburg (Germany)



Founded in  
August 28, 2015



Employee  
109 people



# HD HMS Americas

## Work Scope

- Technical Service
- Spare Parts Sales
- Warranty & Lifetime Service
- Maintenance Service
- Retrofit Conversion
- Reconditioning
- Training Course

## Warehouse / Workshop

Area  
2,274m<sup>2</sup> (24,477ft<sup>2</sup>)

## Inventory

- Aux. Engine Parts (HiMSEN Engine)
- Main Engine Parts (MAN, WinGD)
- Total 2,000 Types of Engine Parts
- Stock Amount Approx. USD 5.5 M



Founded in  
August 2, 2017



Employee  
25 people



Area 3,296m<sup>2</sup>  
(35,477ft<sup>2</sup>)



## HD HMS Singapore

### Work Scope

- LTSA (Long Term Service Agreement)
- Initial Spare Parts (Critical Spare)
- Technical service / Training Academy
- Spare parts sales
- Warranty & lifetime service
- Retrofit conversion
- Reconditioning
- Health check (M/E, A/E, ACONIS, MSBD, BWTS, etc.)
- Bunkering

### Warehouse

Area  
882.60m<sup>2</sup>

### Inventory

- Aux. Engine Parts (HiMSEN Engine)
- Main Engine Parts (MAN, WinGD)
- Electric Parts (ACONIS/SWBD/ACB)
- Total 5,400 Types of Engine Parts
- Stock Amount Approx. USD 13M



Founded in  
December 5, 2017



Employee  
55 people



## HD HMS Middle East

### Work Scope

- Technical service
- Spare parts sales
- Warranty & lifetime service
- Maintenance service
- Retrofit conversion
- Reconditioning
- Training course

### Warehouse

Area  
574.56m<sup>2</sup>

### Inventory

- Aux. Engine Parts (HiMSEN Engine)
- Main Engine Parts (MAN, WinGD)
- Total 1,200 Types of Engine Parts
- Stock Amount Approx. USD 2.5 M



Founded in  
September 1, 2022



Employee  
17 people





**Headquarter**

477, Bundangsuseo-ro,  
Bundang-gu, Seongnam-si,  
Gyeonggi-do, Republic of Korea

**Service Division**

hms.service@hd.com  
+82-2-479-9637

**Sales Division**

hms.sales@hd.com  
+82-70-8670-1122

**Power Plant Team**

powerplant@hd.com  
+82-2-479-9912

**Digital Transformation Division**

smart@hd.com  
+82-2-479-9824/9871

**Bunkering Team**

bunkering@hd.com  
+82-2-479-9825

- Headquarter
- Subsidiary & Warehouse
- Branch Office

**Subsidiaries**

**HMST**

Centum Science Park, 79,  
Centum jungang-ro, Haeundae-gu, Busan,  
48058, Korea

**Europe**

George Hintzenweg 81, Lotus B, 7F,  
3068AX Rotterdam, The Netherlands  
SHIPSERV ID: 240571  
sales.nl\_1@hd.com (Greek Customers)  
sales.nl\_2@hd.com (All)  
service.nl@hd.com (All)

**Americas**

16610 Barker Springs Rd, Houston, TX  
77084, United States / sales.us@hd.com /  
SHIPSERV ID 251590

**Singapore**

Asia Square Tower1, 8 Marina View,  
#36-04, Singapore 018960, Singapore /  
sales.sg@hd.com /  
SHIPSERV ID 252426

**Middle East**

B617, JAFZA ONE, Jebel Ali Freezone,  
Dubai, UAE / sales.ae@hd.com /  
technical.ae@hd.com

**Branch Offices**

**Hamburg (Germany)**

Neuer Wall 10, 20354, Hamburg, Germany  
/ hamburg.de@hd.com

**Athens (Greece)**

8F, 203 Leof. Andrea Siggrou, Nea  
Simirni, 171 21, Athens Greece /  
athens.gr@hd.com

**Tokyo (Japan)**

913 9F, North Wing, Yurakucho Denki Bldg.  
1-7-1, Yuraku-cho, Chiyoda-ku Tokyo  
100-0006, Japan

**Taoyuan (Taiwan)**

Rm.1813, 18F-1, No.83, Sec. 1, Nankan  
Rd., Luzhu Dist., Taoyuan City 338, Taiwan  
R.O.C

**Ningbo (China)**

No.88 Xuedoushan Road,  
Daxie Development Zone, Beilun District,  
Ningbo, China

**Panama**

PH Torre Global Bank, Calle 50,  
Corregimiento de San Francisco, Ciudad  
de Panamá

